

Clearances

"A"
Horizontal distance to adjacent surface
100mm if smooth, 325mm if irregular

Anchors
Horizontal & Vertical 3 minimum (see installation information) for further details of substrate requirements and type
(Only use the fixation angles in the upper level)

Platform floor finish
Standard - Aluminium chequer plate

Electrical supply (Main switch)
1ph L, N, PE, 3 x 2,5mm² 16A

Technical Data
Rated capacity: 400kg / 2 person
Speed: 0,08m / s
Drive: 3,0kW Electrical motor / Belt drive
Electrical Connection: Single phase, 3 x 2,5mm²
Control voltage: 24Volts
Soft start / Stop by frequency inverter

VIEW1 (1:20)

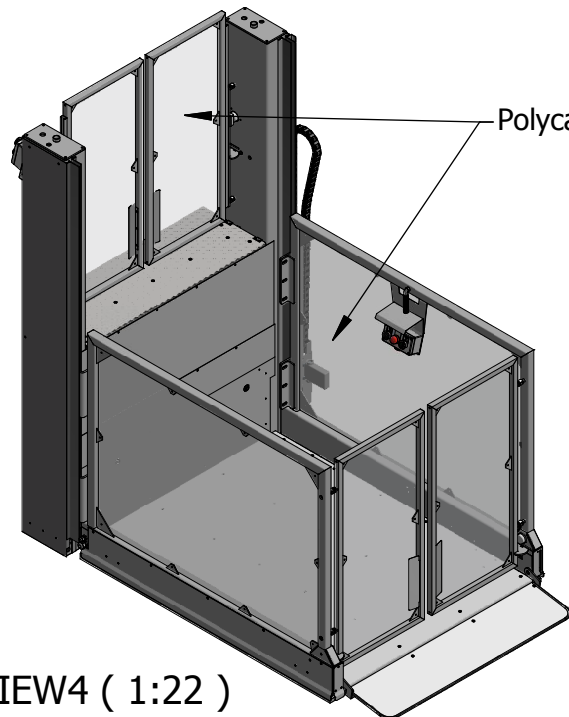
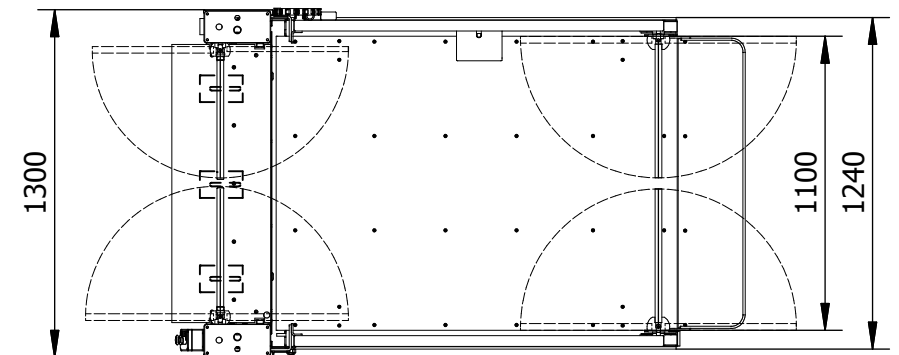
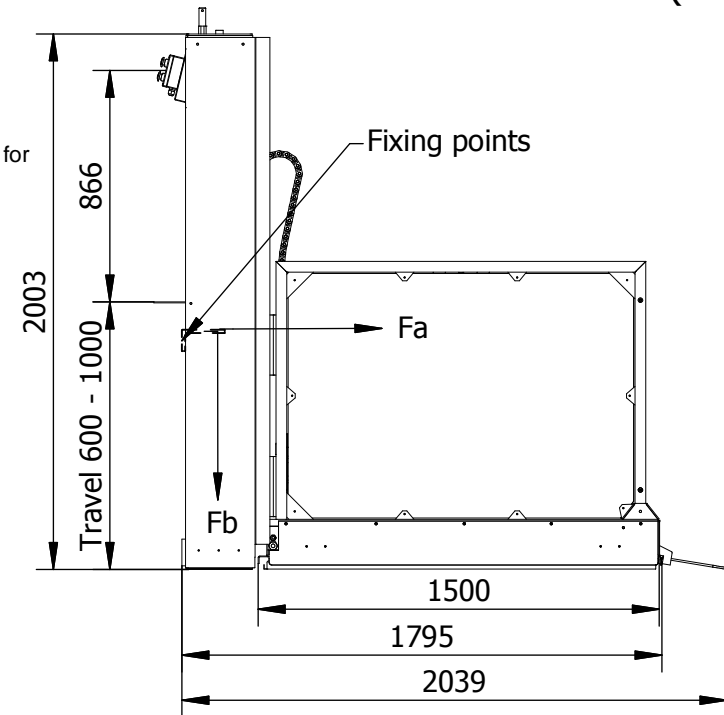

Polycarbonate

HORIZONTAL FORCES	
Fixing height mm	Total Anchor Force Fa, kN
400	25,8
600	17,2
800	12,9
1000	10,3
1200	8,6
1400	7,4
1600	6,5
1800	5,7
2000	5,2
2200	4,7
2400	4,3
2600	4
2800	3,7

Fb= Vertical force of 10kN spread over area of 1300 x 250mm

VIEW4 (1:22)

Designed by Markku	Checked by	Approved by	Date 2017-10-16	Date 2012-03-07	Lh=1000
MPR LIFTS AB			Strategos Superior std		
			16009	Edition 2	Sheet 1 / 1